

**ANNULAR TORQUE TRANSDUCER AND AMPLIFIER  
FOR USE WITH ELECTRONIC TRANSDUCER SYSTEM (E.T.S)**





# CONTENTS

<b>Introduction</b>	<b>2</b>
<b>Specifications</b>	<b>2</b>
<b>Amplifier and Transducer Connections</b>	<b>3</b>
Amplifier	3
Amplifier Controls	4
Amplifier Pin Layout	4
Annular Torque Transducer Wiring Diagram	5
<b>Annular Transducer to Pneutorque<sup>®</sup> Conversion Chart</b>	<b>6</b>
<b>Torque Tightening for Reaction Plate Bolts</b>	<b>6</b>
<b>Transducer Lead for ETS</b>	<b>7</b>
<b>Application of Annular Transducers on Handtorque<sup>™</sup> Gearboxes</b>	<b>8</b>

# INTRODUCTION

The ETS Annular Torque Transducer comes with its own matching amplifier module and shares the same serial and model number. Transducers can be calibrated in either N·m, lbf·ft or lbf·in as standard, but other units of Torque are available i.e. cN·m, dN·m, Kgf·cm and Kgf·m.

The transducer torsion tube is made from heat treated stainless steel on to which are bonded strain gauges which are wired to form a Wheatstone bridge. The strain gauges vary their resistance in direct proportion to the Torque applied. The small change in resistance causes a change in voltage across the bridge that is then amplified by the amplifier module.

The amplifier module is calibrated to each transducer and at it's heart is an Instrumentation Amplifier. Housed within the amplifier module are the bridge balance potentiometers, gain setting potentiometer and bridge test potentiometer along with the range and decimal point coding resistors. The whole is potted in silicon rubber within a plastic shell.

The amplifier operates from supplies of a +/- 10v and a constant current of 20mA which is delivered to the bridge via the zero network. The output voltage from the amplifier is fed to the internal circuitry of the ETS.

# SPECIFICATIONS

Accuracy:	See calibration certificate supplied with transducer.
Amplifier Output:	1.0000 volts Full Scale Defection for N·m. 1.3558 volts Full Scale Defection for lbf·ft. 1.1299 volts Full Scale Defection for lbf·in. 0.9807 volts Full Scale Defection for Kgf·m
Amplifier Power Requirement:	+/- 10v D.C. Regulated.
Constant Current:	20mA +/- .01 mA
Operating Temperature Range:	-10°C - +50°C
Storage Temperature Range:	-20°C - +70°C
Temperature Co-efficient:	<+/- 0.01%/°C. Full Scale Defection on zero <+/- 0.03%/°C. Full Scale Defection on span
Maximum Working Overload:	120% of rated capacity
Absolute Maximum Torsion:	150% of rated capacity

**NOTE: If equipment is used in a manner not specified by the manufacturer, the protection provided by the equipment could be impaired.**

# AMPLIFIER AND TRANSDUCER CONNECTIONS

## Amplifier

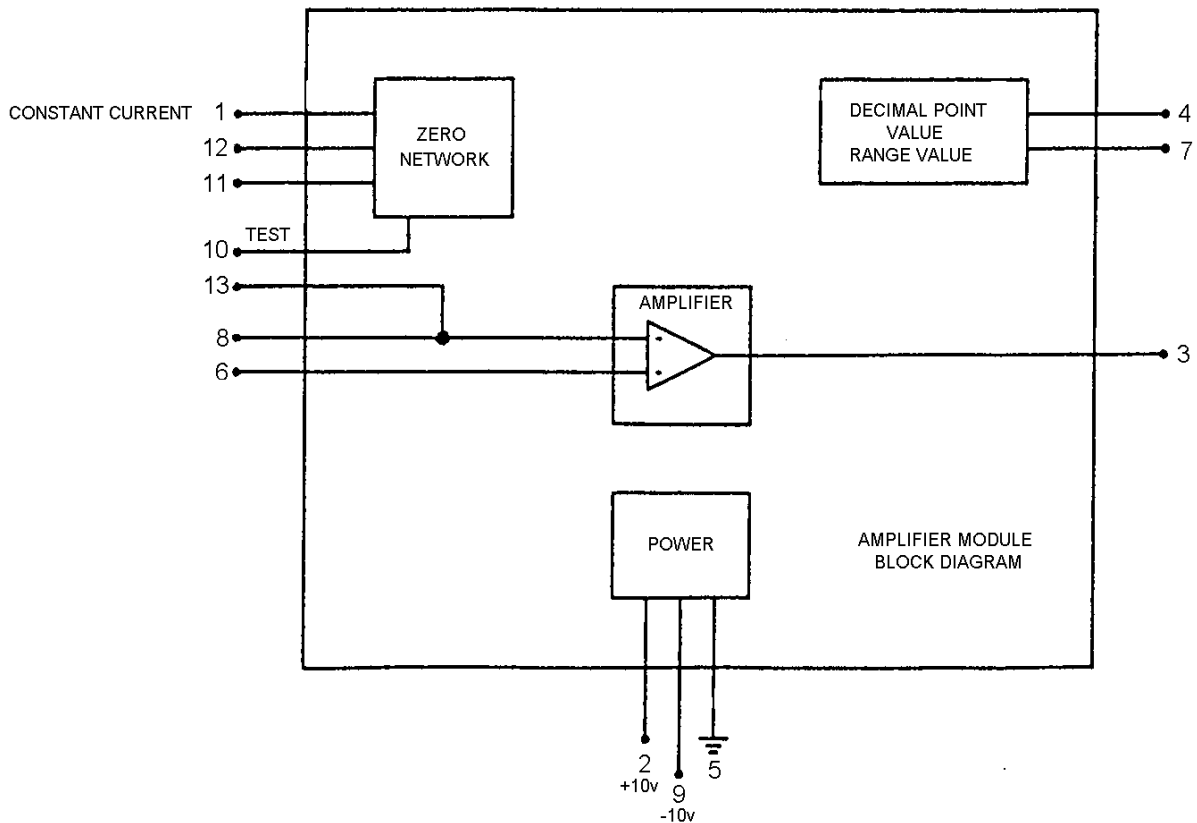

- Pin 1: Constant current 20mA. input to amplifier.
- Pin 2: +10 volt supply.
- Pin 3: Amplifier output.
- Pin 4: Select decimal point output to ETS.
- Pin 5: 0v common, (Connected to Pin F of Transducer via Transducer lead).
- Pin 6: Input from Strain Gauge Bridge, (Connected to Pin A of Transducer via Transducer lead).
- Pin 7: Select Range output to ETS.
- Pin 8: Input from Strain Gauge Bridge, (Connected to Pin B of Transducer via Transducer lead).
- Pin 9: -10 volt supply.
- Pin 10: Test switch input, Shorted to Pin 11 when Test button pressed.
- Pin 11: Supply to Bridge from amplifier, (Connected to Pin D of Transducer via Transducer lead).
- Pin 12: Supply to Bridge from amplifier, (Connected to Pin C of Transducer via Transducer lead).
- Pin 13: Not Used.

## Amplifier Controls

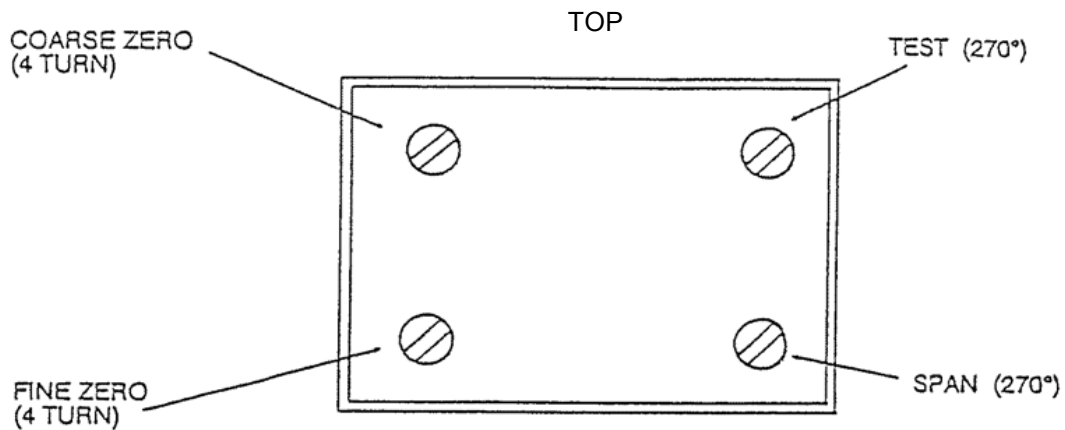

The adjustments available are as follows:

**Fine Zero:** To remove any temperature drift effect or non-zero reading.

**Coarse Zero:** Used for initial bridge balancing, this potentiometer is covered by the label and should not need adjustment.

**Test:** When the TEST switch on the ETS back panel is pushed and held in, the ETS display should read the full scale capacity to which the transducer has been calibrated. This is only for indication purposes only and not a calibration check. This potentiometer is covered by the label and should only need adjustment if the span potentiometer is adjusted.

**Span:** This potentiometer is used to calibrate the amplifier to the transducer when the full scale Torque is applied to the transducer. This potentiometer is covered by a green tamper proof label and should only need adjustment if recalibrating the transducer.

## Amplifier PIN Layout

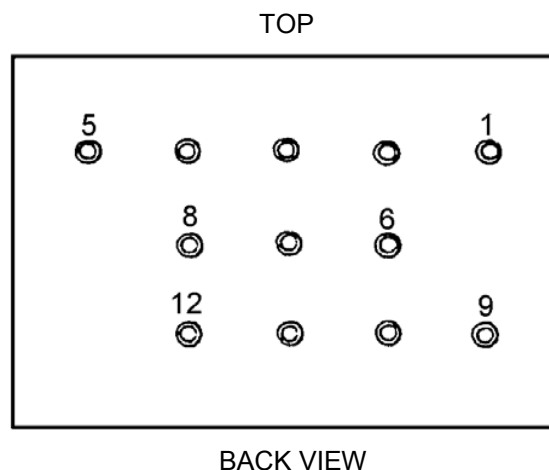

# Annular Torque Transducer Wiring Diagram

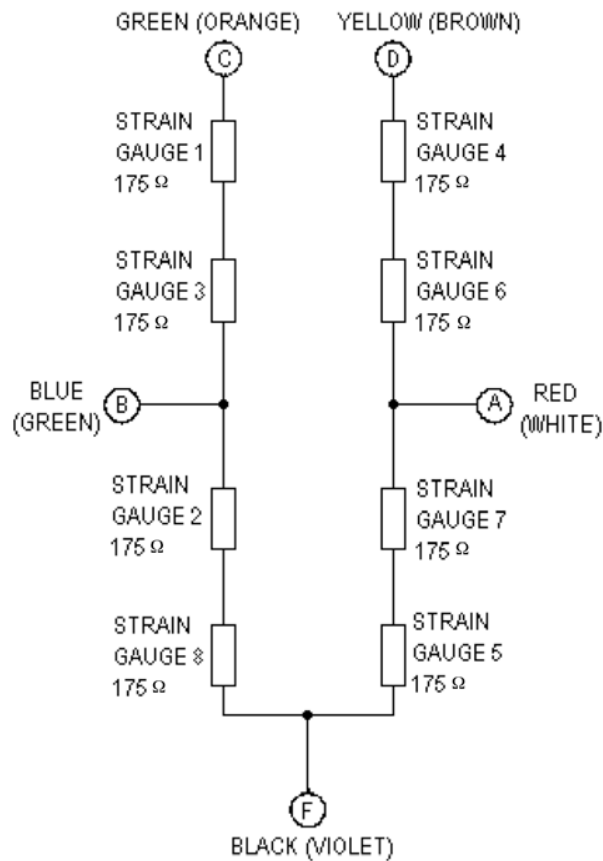

**NOTE:** Colours in brackets refer to transducers pre August 2000.

Resistance Between Terminals	
A to F	350 OHMS
B to F	350 OHMS
C to F	700 OHMS
D to F	700 OHMS
C to D	1400 OHMS

Bridge Signals	
A	Signal Out
B	Signal Out
C and D	Positive Excitation
F	Negative Excitation

# ANNULAR TRANSDUCER TO PNEUTORQUE® CONVERSION CHART

Pneutorque® Model	Output Torque of Pneutorque®	Annular Transducer Capacity	Part Number
PT1	500 lbf·ft	1000 lbf·ft	50071.ETS
	680 N·m	1000 N·m	50070.ETS
PT1A	900 lbf·ft	1000 lbf·ft	50071.ETS
	1200 N·m	1500 N·m	50072.ETS2
PT2	1250 lbf·ft		
	1700 N·m		
PT5	2500 lbf·ft	2500 lbf·ft	50073.ETS
	3400 N·m	2500 N·m	50074.ETS
PT6	2500 lbf·ft		
	3400 N·m		
PT7	4500 lbf·ft	5000 lbf·ft	50075.ETS
	6000 N·m	5000 N·m	50076.ETS
PT9	7000 lbf·ft	7000 lbf·ft	50077.ETS2
	9500 N·m	10000 N·m	50078.ETS
PT11	14700 lbf·ft	10000 lbf·ft	50082.ETS
	20000 N·m	10000 N·m	50081.ETS
PT13	35000 lbf·ft	50000 lbf·ft	50080.ETS
	47000 N·m	50000 N·m	50085.ETS
PT14	73500 lbf·ft	100000 lbf·ft	50154.ETS
	100000 N·m	100000 N·m	50143.ETS

## TORQUE TIGHTENING FOR REACTION PLATE BOLTS

Bolt Size	lb·ft	N·m
2 BA	7	9
¼ BSF	14	19
⅜ BSF	55	75
M 5	9	12
M 6	13	17.5
M 8	32	43
M 10	61	83
M 12	115	155
M 16	230	310



# TRANSDUCER LEAD FOR ETS (Not Included)

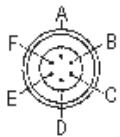
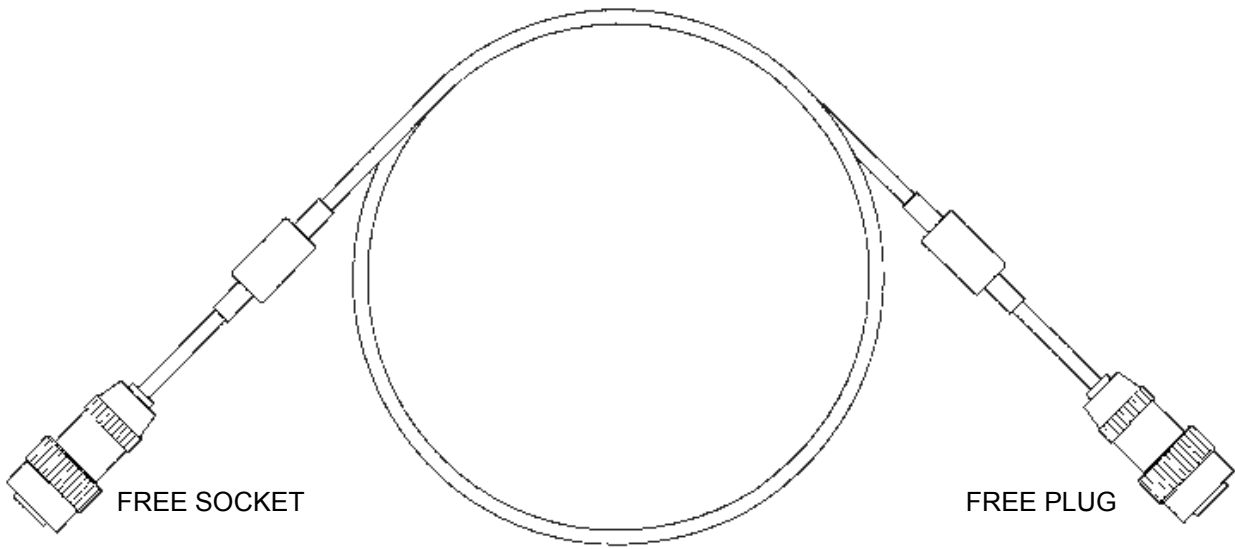

Free Socket viewed from cable end

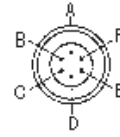

Free Plug viewed from cable end

## Cable Connectors

A	Red (White)
B	Blue (Green)
C	Green (Red)
D	Yellow
E	-
F	Black (Blue)

**NOTE:** Colours in brackets refer to transducer leads pre August 2000.

# APPLICATION OF ANNULAR TRANSDUCERS ON HANDTORQUE™ GEARBOXES

To appreciate the operation of an Annular Transducer on a Handtorque™ gear box, users need to be aware of the following:

TORQUE ON TRANSDUCER (T reaction) = OUTPUT SQUARE DRIVE TORQUE (T output) - INPUT TORQUE (T input)

The reason for this is that the annular transducer measures the reaction torque, not the applied torque and part of the reaction torque is taken by the operator when the input to the multiplier is loaded

For the Handtorque™ gearbox shown below there are three external torques applied.

1. The torque applied by the operator through the torque wrench.  
(  $T_{input} = F_{in} \times L_{in}$  )
2. The torque applied to the annulus by the reaction force acting on the reaction plate.  
(  $T_{reaction} = F_r \times L_r$  )
3. The resistive torque of the fastener applied to the gearbox through the drive square.  
(  $T_{output}$  )

This phenomenon only exists while the multiplier input is being loaded, so if an Anti Wind-up Ratchet is used, measured torque will equal output torque when the input torque has been released.

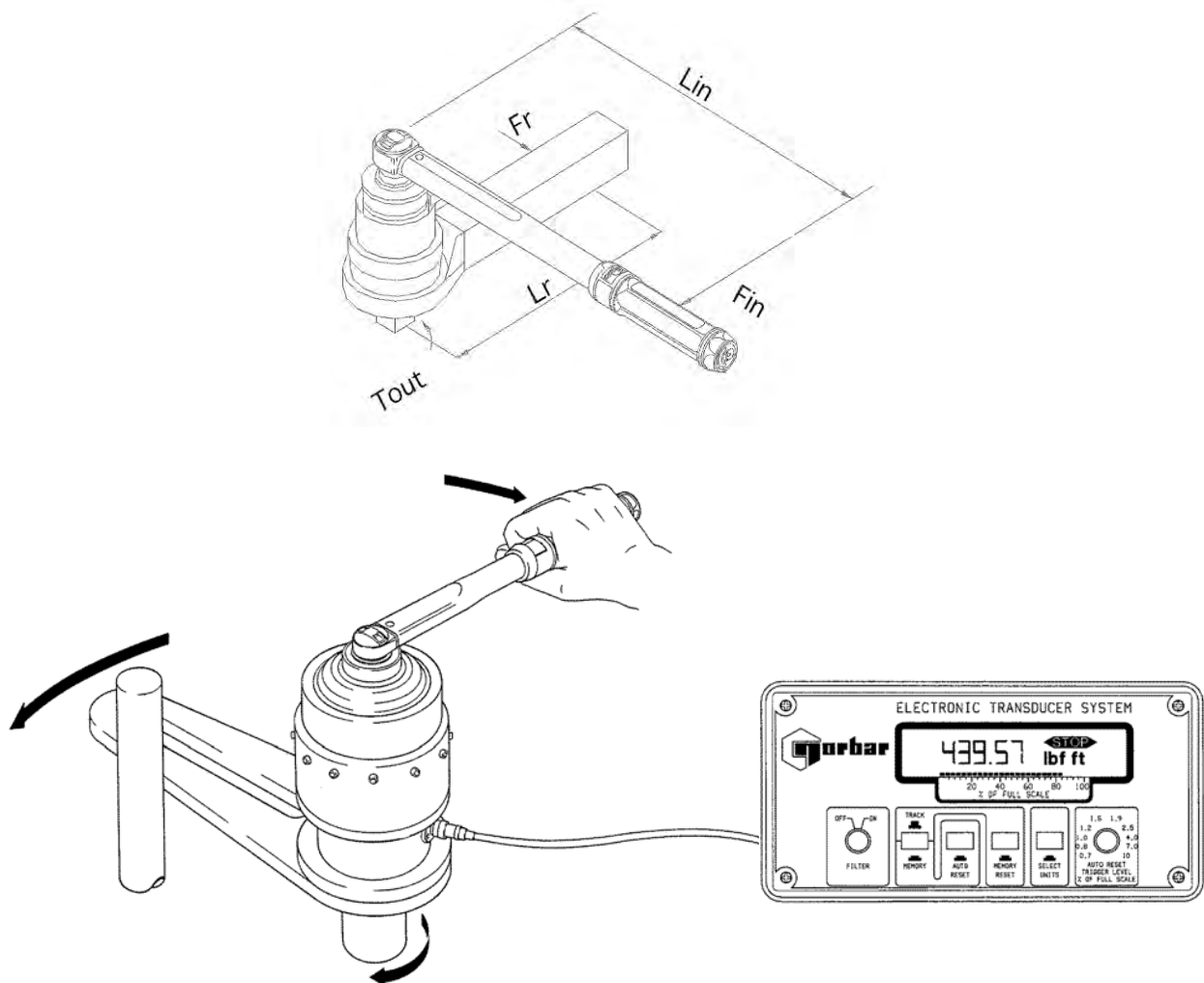

**NORBAR TORQUE TOOLS LTD**

Beaumont Road, Banbury,  
Oxfordshire, OX16 1XJ  
UNITED KINGDOM  
Tel + 44 (0)1295 270333  
Email [enquiry@norbar.com](mailto:enquiry@norbar.com)

**NORBAR TORQUE TOOLS PTE LTD**

194 Pandan Loop  
#07-20 Pantech Business Hub  
SINGAPORE 128383  
Tel + 65 6841 1371  
Email [singapore@norbar.com.au](mailto:singapore@norbar.com.au)

**NORBAR TORQUE TOOLS PTY LTD**

45-47 Raglan Avenue, Edwardstown,  
SA 5039  
AUSTRALIA  
Tel + 61 (0)8 8292 9777  
Email [enquiry@norbar.com.au](mailto:enquiry@norbar.com.au)

**NORBAR TORQUE TOOLS (SHANGHAI) LTD**

E Building-5F, no. 1618 Yishan Road,  
Minhang District, Shanghai  
CHINA 201103  
Tel + 86 21 6145 0368  
Email [sales@norbar.com.cn](mailto:sales@norbar.com.cn)

**NORBAR TORQUE TOOLS INC**

36400 Biltmore Place, Willoughby,  
Ohio, 44094  
USA  
Tel + 1 866 667 2279  
Email [inquiry@norbar.us](mailto:inquiry@norbar.us)

**NORBAR TORQUE TOOLS INDIA PVT. LTD**

Plot No A-168, Khairne Industrial Area,  
Thane Belapur Road, Mahape,  
Navi Mumbai – 400 709  
INDIA  
Tel + 91 22 2778 8480  
Email [enquiry@norbar.in](mailto:enquiry@norbar.in)

**NORBAR TORQUE TOOLS (NZ) LTD**

B3/269A Mt Smart Road  
Onehunga, Auckland 1061  
NEW ZEALAND  
Tel + 64 9579 8653  
Email [nz@norbar.com.au](mailto:nz@norbar.com.au)

**[www.norbar.com](http://www.norbar.com)**